



INSTRUCTION MANUAL
Detectors Incorporated
Model D371SS 3IR + UV
Flame Detector





Table of Contents

INTRODUCTION	3	DETECTOR CONNECTIONS	14
Product Description.....	3	Wiring Connections.....	14
Specifications.....	4	M25 Conduit Entries.....	14
Electrical.....	4	Connector Plugs J1 and J2.....	15
Environmental.....	4	Wiring Schematic.....	15,16
Mechanical.....	4		
Detector Sensors, LED		OPERATION AND STARTUP	17
Indicators and Connection.....	5	Powering the Detector.....	17
Equipment Label Certificate		LED Status Indicators.....	17,18
Numbers and Hazardous Location Ratings.....	6, 7	Detector Self-Test.....	18
		Alarm Test.....	19
INSTALLATION	8		
CONDITION OF USE/GUIDELINE	8	MAINTAINANCE	19
The Proper Detector.....	8	Maintenance Requirements	19
Field-of-View.....	8, 9	Detector Inspection.....	19
Positioning.....	9	Periodic Detector Testing	20
Sensitivity Settings.....	9	Functional Testing.....	20
Environmental Conditions.....	10	Inspecting the Wiring Compartment.....	20
Wiring.....	10		
		D371 DETECTOR RESPONSE CHARACTERISTICS	21
DETECTOR DIMENSIONS	10	Performance Testing	21,22
		Immunity to False Alarms	23 - 25
MOUNTING THE DETECTOR	11		
Swivel Arm Assembly		TROUBLESHOOTING	26
(P/N: DA-001).....	10,11		
		EVENT LOG & FIRE GRAPH	28 - 30
DETECTOR OUTPUT SIGNALS	11		
Outputs.....	11	ACCESSORIES	31 - 32
Relay Latching / Non-Latching.....	12		
4-20 mA Output.....	12	PRODUCT SUPPORT	32
RS485 ModBus.....	12	Technical and Customer Support	32
CONFIGURING THE DETECTOR	12	WARRANTY	33
Default Settings.....	12		
Factory Default Relay Settings.....	12	APPENDIX "A"-	
		DETECTOR ORDERING INFORMATION	34
WIRING THE DETECTOR	13		
Wiring.....	13	APPENDIX "B"-	
Conduit.....	13	APPROVALS & CERTIFICATIONS	35
Cable Glands.....	13		
Shielded Cable.....	13		
Wire Gauge.....	13		



1.0 Introduction

Model **D371SS** 3IR + UV



1.1 Product Description

The Model **D371SS** is a Multi-Spectrum 3IR + UV flame detector designed and optimized for detection of Hydrocarbon and Non-Hydrocarbon based fires while rejecting False Alarm Sources. The Model **D371SS** senses the IR radiation in 3 discrete bands of Infrared in the range of 2-5 microns.

The Model **D371SS** combines the benefits 3IR flame detector with the addition of a highly sensitive UV sensor for applications requiring a long-range UV/IR flame detector. The detector is offered in explosion-proof 316 stainless steel enclosures rated NEMA 4X / IP66 / IP67, as standard option. The **D371SS** detector can be used as stand-alone device or it can interface with any PLC or approved fire alarm panel.

"D371SS Flame Detector includes a non-replaceable coin cell. Do not attempt to replace the coin cell at any time."





1.2 Specifications

1.2.1 General

Field-of-View:	90° Horizontal, 90° Vertical
Spectral Sensitivity:	UV: 180-260 nanometers IR: 2-5 microns (3 discrete bands)
Sensitivity Setting:	High, Medium, Low
Response Time:	3-5 Seconds
Detection Range:	1' x 1' n-Heptane fire: Model D371SS : 200 ft. (61 m)

1.2.2 Electrical

Operating Voltage:	24 VDC nominal (18-31), Regulated
Power Consumption:	Standby: 60 mA @ 24 VDC Alarm: 90 mA @ 24 VDC Heater: 180 mA additional (Heater is optional and must be specified when ordering)
Relays Outputs:	Alarm / Fault / Auxiliary SPDT—contacts rated 2A @ 24 VDC Alarm & Auxiliary relays: De-Energized Fault relay: Energized Aux. relay settings: 0.3, 3, 10, 20 seconds Factory Default for Aux. Relay: 3 Seconds
Analog Output:	0-20 mA Stepped - Source
Communication:	RS485 ModBus RTU
Visual Indications:	Green LED - Normal Red LED - Alarm Amber LED - Fault
Conduit Entries	(2) M25 Optional M25 X 3/4" adapter available
Wiring:	12 AWG (3.3 mm ²) - 22 AWG (.33mm ²)

1.2.3 Environmental

Humidity Range:	5 to 95% relative humidity, non-Condensing
Temperature Range:	-40 to + 185°F (-40 to + 85 °C)
Enclosure Type:	NEMA 4 & 4X, IP66, IP67

1.2.4 Mechanical

Enclosure Material:	316 Stainless Steel, Standard
Weight:	10 lbs. (4.5 kg)
Mounting:	Stainless Steel Swivel Arm—Optional
Weight:	6.6 lbs. (3 kg)



1.2.5 Detector Sensors, LED Indicators and Connections

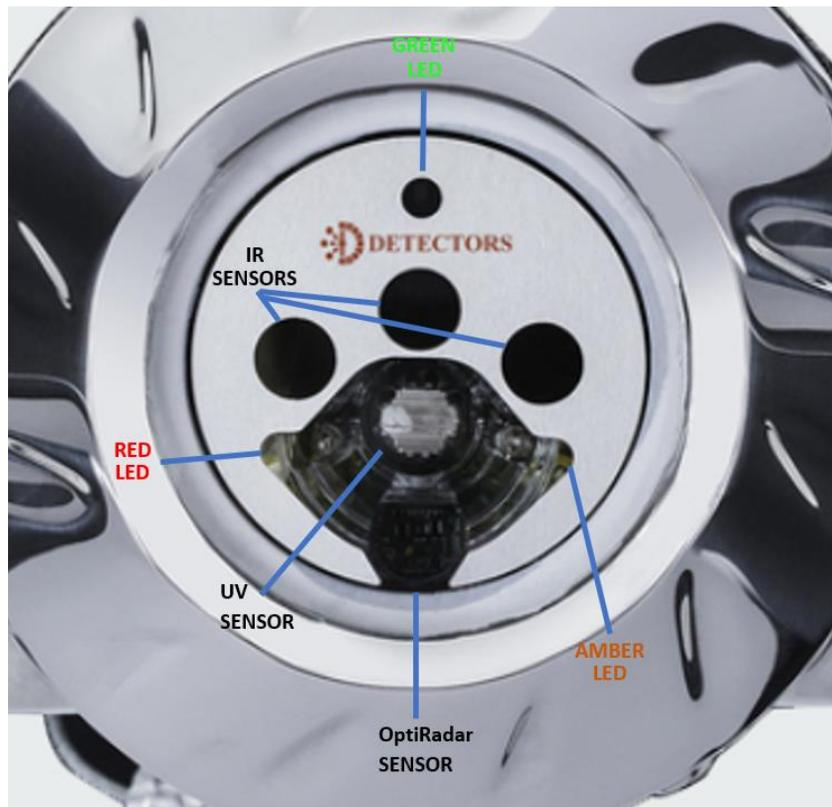



1.2.6 Equipment Label, Certificate #s and Hazardous Location ratings

1.2.6.1 Label: LAB-RANG-0006

Type	Ratings
Model #	D371SS-XXXX-NX
US	FM17US0336X Class I, Division 1, Groups A, B, C, and D T6...T4 Ta=-40°C to Tx Class II/III, Division 1, Groups E, F and G T6...T4 Gb Ta=-40°C to +Tx Class I, Zone 1 AEx db IIC T6...T4 Gb Ta=-40°C to +Tx Zone 21 AEx tb IIIC T85°C...T135°C Db Ta=-40°C to Tx Type 4X and IP66/67 For XP, DIP and AEx db, temperature code is T6 when Tx is +60°C, T5 when Tx is +75°C or T4 when Tx is +85°C For AEx tb, temperature code is T85°C when Tx is +60°C, T100°C when Tx is +75°C or T135°C when Tx is +85°C. Refer to installation instruction/manual
Canada	FM17CA0120X Class I, Division 1, Groups A, B, C, and D T6...T4 Ta=-40°C to Tx Class II/III, Division 1, Groups E, F and G T6...T4 Gb Ta=-40°C to +Tx Ex db IIC T6...T4 Gb Ta=-40°C to +Tx Ex tb IIIC T85°C...T135°C Db Ta =-40°C to +Tx Type 4X and IP 66/67 For XP, DIP and Ex db, temperature code is T6 when Tx is +60°C, T5 when Tx is +75°C or T4 when Tx is +85°C For Ex tb, temperature code is T85°C when Tx is +60°C, T100°C when Tx is +75°C or T135°C when Tx is +85°C Refer to installation instruction/manual
ATEX	FM17ATEX0101X II 2 G Ex db IIC T6... T4 Gb Ta=-40°C to +Tx IP66/67 For Ex db temperature code is T6 when Tx is +60°C, T5 when Tx is +75°C, T4 when Tx is +85°C For Ex db, temperature code is T85°C when Tx is +60°C, T100°C when Tx is +75°C or T135°C when Tx is +85°C Refer to Installation instruction/manual
IECEX	IECEX FMG 17.0034X Exdb IIC T6...T4 Gb Ta=-40° to +Tx Ex tb IIIC T85°C...T135°C Db Ta =-40°C to +Tx IP66/67 T6 when Tx is +60°C, T5 when Tx is +75°C, T4 when Tx is +85°C T85°C when Tx is +60°C, T100°C when Tx is +75°C, T135 when Tx is +85°C Refer to installation instruction/manual
CE	Meets or Exceeds MIL-STD 810C. In Compliance with FM-3260-2001
Warning	CAUTION: OPEN CIRCUIT BEFORE REMOVINF COVER ATTENTION: OUVRIER LE CIRCUIT AVANT DENLEVER LE COUVERCLE WARNING-DO NOT OPEN WHE AN EXPLOSIVE ATMOSPHERE IS PRESENT Ne Pas Ouvrir En Prence Dune Atmosphere Explosive FOR DIVISIONS, SEAL CONDUIT WITHIN 450 mm OF ENCLOSURE For Zone installations, install a seal within 50mm of the enclosure Pour les zones Canadiennes, un scellement doit etre installe a mohs de 50mm du boiler WARNING-Do not open when energized or an explosive atmosphere is present



1.2.6.2

Label: LAB-RANG-0008

Type	Ratings
Model #	D371SS-XXXX-MC
US	FM17US0336X Class I, Division 1, Groups A, B, C, and D T6...T4 Ta=-40°C to Tx Class II/III, Division 1, Groups E, F and G T6...T4 Gb Ta=-40°C to +Tx Class I, Zone 1 AEx db IIC T6...T4 Gb Ta=-40°C to +Tx Zone 21 AEx tb IIIC T85°C...T135°C Db Ta=-40°C to Tx Type 4X and IP66/67 For XP, DIP and AEx db, temperature code is T6 when Tx is +60°C, T5 when Tx is +75°C or T4 when Tx is +85°C For AEx tb, temperature code is T85°C when Tx is +60°C, T100°C when Tx is +75°C or T135°C when Tx is +85°C. Refer to installation instruction/manual
Canada	FM17CA0120X Ex db IIC T6...T4 Gb Ta=-40°C to +Tx Ex tb IIIC T85°C...T135°C Db Ta =-40°C to +Tx Type 4X and IP 66/67 For XP, DIP and Ex db, temperature code is T6 when Tx is +60°C, T5 when Tx is +75°C or T4 when Tx is +85°C For Ex tb, temperature code is T85°C when Tx is +60°C, T100°C when Tx is +75°C or T135°C when Tx is +85°C Refer to installation instruction/manual
ATEX	FM17ATEX0101X II 2 G Ex db IIC T6... T4 Gb Ta=-40°C to +Tx IP66/67 For Ex db temperature code is T6 when Tx is +60°C, T5 when Tx is +75°C, T4 when Tx is +85°C For Ex db, temperature code is T85°C when Tx is +60°C, T100°C when Tx is +75°C or T135°C when Tx is +85°C Refer to Installation instruction/manual
IECEX	IECEx FMG 17.0034X Exdb IIC T6...T4 Gb Ta=-40° to +Tx Ex tb IIIC T85°C...T135°C Db Ta =-40°C to +Tx IP66/67 T6 when Tx is +60°C, T5 when Tx is +75°C, T4 when Tx is +85°C T85°C when Tx is +60°C, T100°C when Tx is +75°C, T135 when Tx is +85°C Refer to installation instruction/manual
CE	Meets or Exceeds MIL-STD 810C. In Compliance with FM-3260-2001
Warning	CAUTION: OPEN CIRCUIT BEFORE REMOVINF COVER ATTENTION: OUVRIER LE CIRCUIT AVANT DENLEVER LE COUVERCLE WARNING-DO NOT OPEN WHE AN EXPLOSIVE ATMOSPHERE IS PRESENT Ne Pas Ouvir En Predence Dune Atmosphere Explosive FOR DIVISIONS, SEAL CONDUIT WITHIN 450 mm OF ENCLOSURE For Zone installations, install a seal within 50mm of the enclosure Pour les zones Canadiennes, un scellement doit etre installe a mohs de 50mm du boiler WARNING-Do not open when energized or an explosive atmosphere is present



2.0 Installation

2.1 Specific Conditions of use:

- 2.1.1 The **D371SS** IR3 with Enhanced UV Flame Detector Includes flamepath joints, consult with Detectors Inc if repair of the flamepath joints is necessary.
- 2.1.2 The temperature code of the **D371SS** IR3 with Enhanced UV Flame Detector is based on the following maximum ambient temperatures

<i>Temperature Codes (T-Codes)</i>		<i>Maximum Ambient Temperatures (Tx)</i>
<i>Gases/Vapors</i>	<i>Dust</i>	
<i>T6</i>	<i>T85°C</i>	<i>+60°C</i>
<i>T5</i>	<i>T100°C</i>	<i>+75°C</i>
<i>T4</i>	<i>T135°C</i>	<i>+85°C</i>

2.2 Guideline

There are several important factors that must be considered when installing flame detectors in order to optimize their performance. Below are the guidelines to be observed as a minimum:

2.2.1 The Proper Detector

Verify that you have purchased and received the right detector for your application. Survey the hazard area to ensure that there are adequate number of detectors for proper coverage. This is determined by the Field-of-View of detector, it's distance from the hazard area and the sensitivity setting. When in doubt, please contact the factory for additional information.

2.2.2 Field-of-View

Field-of-View (FOV) or cone of vision of a flame detector is a three-dimensional conical volume with the apex at the center of flame detector and extending outward. FOV is normally determined by the detector enclosure, size and shape of the window and the sensors placement. FOV from



various manufacturers can vary from 70 - 120 degrees wide. A wide FOV does not necessarily mean the flame detector is better; different applications require different FOV for the area coverage. Smaller hazardous areas and certain applications require precise coverage so that the FOV of the detector does not extend beyond the area intended to be covered.



Verified Field of View Graphics

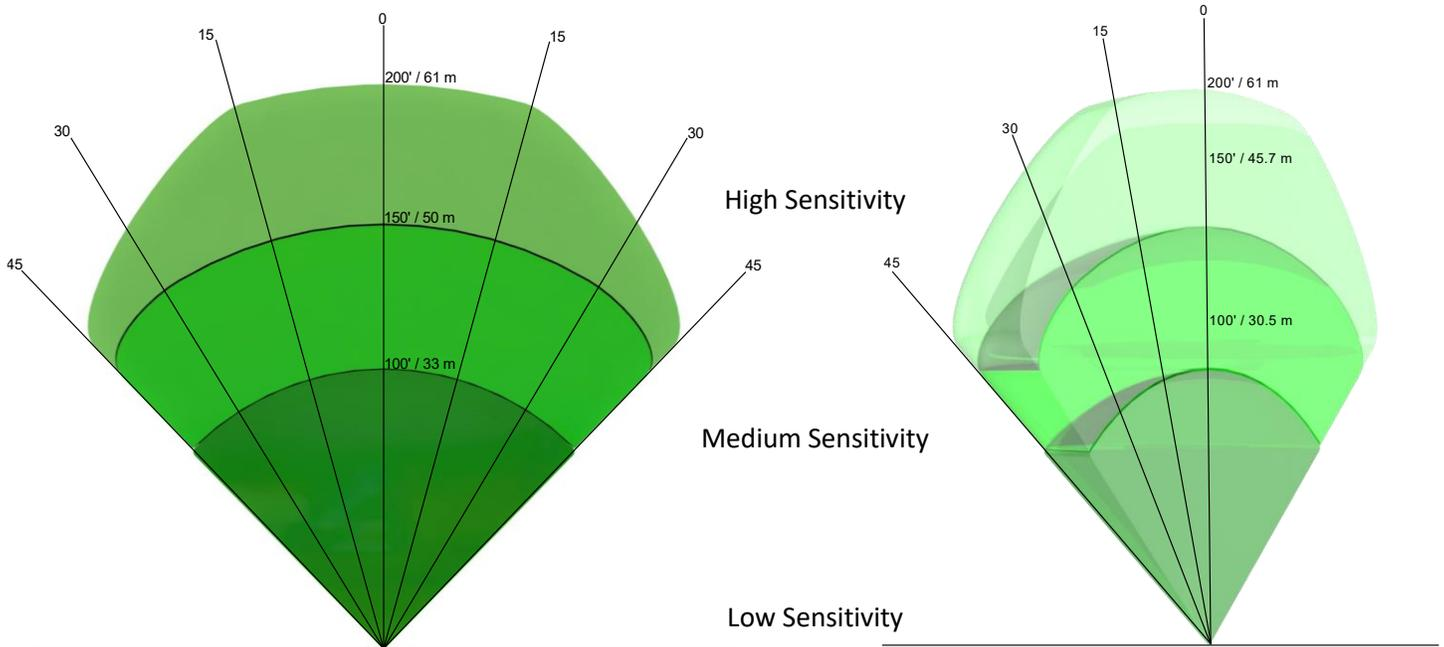

Traditional Field of View Chart

Conical Field of View

2.2.3 Positioning

The detector should be installed such that the center of the detector is aimed at the center of the area to be protected (hazard area). Detectors should be installed above the hazard area pointing downward at an angle between 35-55 degrees from horizontal with no obstruction of the Field-of-View. Detector height generally should be approximately 1½ to 2½ times the height of tallest object in the hazard area. The height may vary depending on the application, indoor/outdoor installation and size of the hazard area. Detector should be easily accessible for maintenance.

2.2.4 Sensitivity Settings

The Model **D371SS** detector has the following sensitivity settings and responses to 12" X 12" n-heptane pan fires within 3-5 seconds.

Table 1

Sensitivity Setting	Distance
High	200 ft. (61 m)
Medium	150 ft. (38.1 m)
Low	100 ft. (22.9 m)

Detector sensitivity setting will depend on the size of the hazard area, distance from detector to hazard area, type of fuel, and size of the fire.



2.2.5 Environmental Conditions

If possible, detectors should be installed so that they are protected from rain, snow, direct sunlight and other intense sources of IR or UV radiation. It is critical to protect the detector against ingress of moisture inside the enclosure. Detector's cover must be tightened per manufacturer's recommended procedure and the conduits openings must be properly sealed to prevent moisture from entering the enclosure.

2.2.6 Wiring

Approved shielded cable must be used to protect the electronics against interference from RFI and EMI. Generally, 18 or 16 gauge shielded cable is recommended. The wire size will depend on the distance from detector to the control system and the number of detectors connected to the same power source. Cable shield should be terminated at a ground lug near the detector.

NOTE: Supply field wiring must be rated at least 25°C greater than the maximum ambient temperature of the application.

2.3 Detector Dimensions

The **D371SS** detector is supplied with 316 Stainless Steel enclosure suitable for installation in Class I, Div. 1 (Zone 1) Hazardous areas. The enclosure is Water-Tight and rated NEMA 4 & 4X with ingress protection of IP67. The enclosure dimensions are as shown in Figure (1).

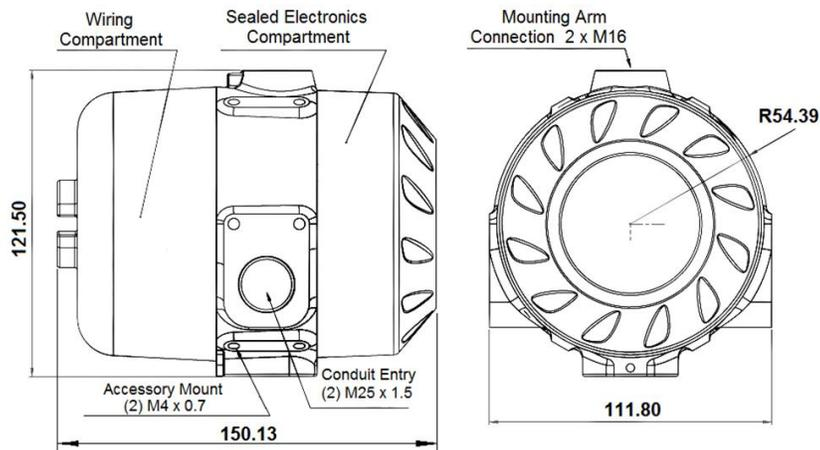

Fig. 1
Detector Dimensions (Dimension in mm)



2.4 Mounting the Detector

Detector should be mounted on a rigid and vibration free surface using the Swivel Arm Assembly Model SM-37 (P/N: DA-001).

2.4.1 Swivel Arm Assembly (P/N: DA-001)

Swivel Arm assembly is fabricated from 316 stainless steel and shipped fully assembled. It consisted of three sections: mounting base, center piece, and detector holding piece. It has a ratchet design allowing detector rotation in vertical and horizontal planes.

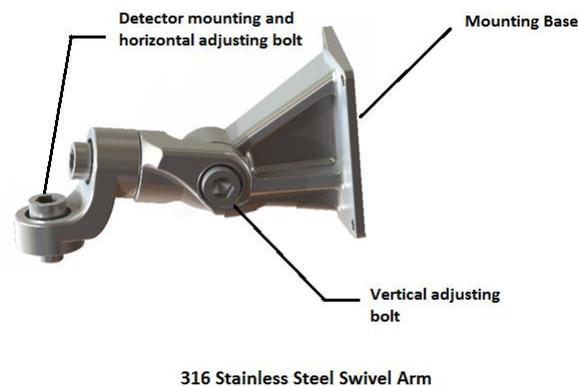

Fig. 2 – Swivel Mounting Arm

To install the Swivel Arm Assembly:

1. Unpack and inspect the Swivel Arm assembly.
2. Place the mounting base on a rigid and flat surface and secure it with (4) 7mm or 1/4" bolts of proper length (bolts not supplied).
3. Place the detector under the Swivel Arm assembly and secure it to the detector holding piece of the Swivels Arm assembly with an M16 bolt supplied with the Swivel Arm assembly, tighten the bolt.
4. Detector can now be adjusted vertically and horizontally by loosening the vertical and horizontal M16 bolts on the Swivel Arm assembly and aiming the detector to the hazard area.

2.5 Detector Output Signals

2.5.1 Outputs

The detector has the following outputs (no power applied):

- Fire Alarm Relay (SPDT) – Normally Open/Normally Closed
- Fault Relay (SPST) – Normally Open
- Auxiliary Relay (SPDT) – Normally Open/Normally Closed
- Analog output: 0-20 mA stepped
- RS-485 ModBus RTU



2.5.2 Relay Outputs: Latching / Non-latching

Detectors are shipped from factory with “Non-Latching” relays as factory standard. If “Latching” relays are required, must be specified when ordering. Please refer to Appendix “A” for optional configurations.

2.5.3 0-20mA Output

A non-isolated 0-20 mA stepped analog output (Current Source) is also provided as standard. Following output levels are defined:

Table 2 - Analog Current output levels

Analog Output (mA)	Detector Status
0.0	Fault - No Power
< 1.0	Fault - General
2.0 ± 0.3	Fault – self-test
4.0 ± 0.3	Normal (no alarm, no fault)
20.0 ± 0.3	Alarm

Maximum loop resistance for the analog output is 800 Ohms.

2.5.4 RS485 ModBus Communication

The detector model **D371SS** is also equipped with a standard RS485 ModBus communication protocol for interfacing with devices or controllers using the Modbus standard. The RS485 communication protocol is also useful in communicating with the detectors for viewing or downloading Event Logs and Fire Charts using a laptop and the optional LabVIEW programming software available from Detectors Inc.

2.6 Configuring the Detector

2.6.1 Default Settings:

Unless specified, The **D371SS** detector is shipped factory configured as described below:

Fire Alarm Relay:	Normally De-Energized, Non-Latching (NO/NC)
Fault Relay:	Normally Energized, Non-Latching (NC)
Auxiliary Relay	Normally De-Energized, Non-Latching (NO/NC)
0-20 mA	Stepped Analog, Sourcing
Communication	ModBus RTU Protocol
Sensitivity Setting	High

2.6.2 Factory Default Relay Settings

All relays with standard configuration are “Non-Latching”. If “Latching” mode is required, it must be specified when ordering.



2.7 Wiring the Detector

2.7.1 Wiring

Detectors shall be wired in accordance with the local codes and standards for the area they are intended for.

Detector shall be wired in accordance with the current National Electrical Code (NFPA 70) for hazardous location wiring procedure in the United State; or according to the local codes in other countries, observing the requirements for Electrical Safety.

2.7.2 Conduit

If conduit is used, conduit type and installation in a Hazardous Area shall comply with the National Electric Code Standard, Article 500. For locations, other than the United States, use of conduit or cable glands shall comply with the local codes. Proper conduit sealing compound must be used to prevent ingress of moisture.

2.7.3 Cable Glands

If Cable Glands are used in Hazardous and Industrial areas, they should meet the North American and International codes and standards for such installations.

2.7.4 Shielded Cable

Shielded cable is highly recommended for protection against RFI and EMI. Where multiple detectors are installed, the wire size will depend on the number of detectors connected to a power supply and the length of cables and the supply voltage. The voltage at any given detector shall not be less than 18 VDC. Normally, 18 or 16-gauge (AWG) wire is adequate for short runs and fewer than 10-12 detectors.

2.7.5 Wire Gauge

Table below is a partial listing of the American Wire Gauge Property and Conductor Size. Using a power supply with 22-28 VDC output rating and the table below, calculations can be performed to obtain the allowable voltage drop across a selected wire gauge in order to maintain minimum of 18 V at each detector connected to the power supply.

Table 3 - American Wire Gauge (AWG) and Properties Table

AWG	Area (mm ²)	Resistance Ohms/1000 ft.	Resistance Ohms/1000 m)
12	3.31	1.59	5.21
14	2.08	2.53	8.28
16	1.31	4.02	13.17
18	0.82	6.39	20.94
20	0.52	10.15	33.20



2.8 Detector Connections

2.8.1 Wiring Connections

Wiring connections are made to connectors inside the rear compartment. The detector has two separate compartments one in the front housing the detector electronics and one in the back containing the PC boards with connector terminal for wiring. Compartments are separated by a physical barrier in order to keep the electronics from being exposed to environment while wiring.

NOTE: For US Zones, the internal grounding terminal must be used. The external grounding terminal is supplementary.

CAUTION: The front cover should not be removed at any time. Removing the electronic module and tampering with the circuit board will void the detector warranty. Contact factory for detector configuration changes requiring access to DIP switches on the face of the detector.

2.8.2 M25 Conduit Entries

There are two M25 conduit entries located at the wiring compartment, one or both conduit entries may be used for routing the cable(s). If only one conduit entry is used, the unused conduit entry must be properly sealed with an approved sealing material similar to Teflon dope or tape. Metal-to-Metal will NOT provide adequate seal against the ingress of moisture. Simply remove the 25 mm plug, apply the sealing compound and re-install the plug to ensure a weather-tight integrity of the wiring compartment.

An M25 x 3/4" adapter will be supplied when 3/4" NPT connections are specified.

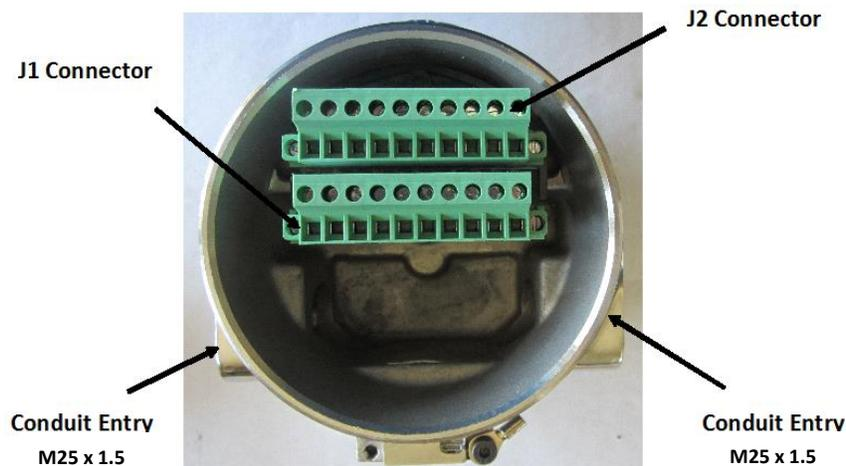

Rear Compartment of Detector with Cover Removed

Fig. 3



2.8.3 Connector Plugs J1 and J2

The connector plugs J1 and J2 can be removed for wiring and re-installed once the wiring is completed. Please note that there are 24VDC (+) and 24VDC (-) terminals on each connector. These terminals are internally connected, and the power may be connected to one connector plug only.

2.8.4 Wiring Schematic

A typical wiring schematic for D371SS detector is shown in Figure (4)

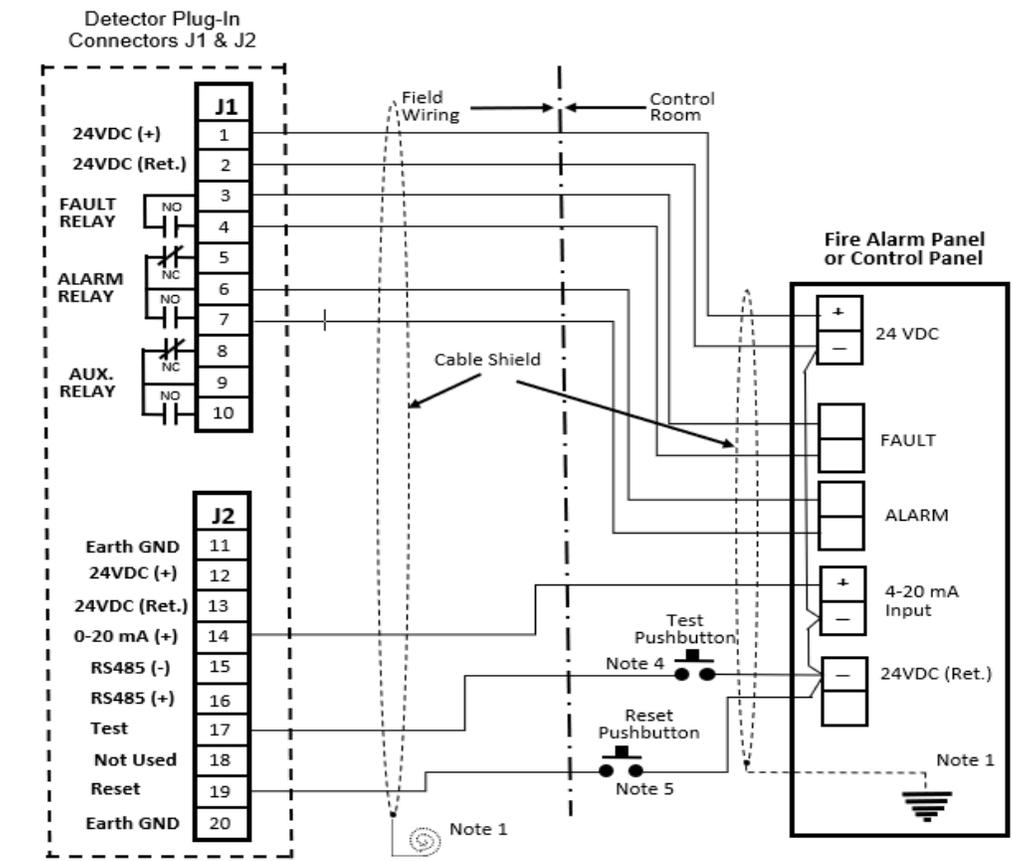

NOTES:

1. Cable shield must be connected to "Earth Ground" at one location preferably at the Fire Alarm or Control Panel only. Coil and tape the cable shield at the detector end.
2. Detector enclosure must be connected to "Earth Ground" at the detector location.
3. All relay contacts shown in static condition with no power applied to detector. When power is applied, Fire and Auxiliary relays will remain De-Energized and Fault relay will energize with contacts closed and no Fault.
4. Connecting or shorting terminal labeled "Test" to 24 VDC (Return) will initiate detector's automatic self-test feature. Detector will cycle through its self-test checking the sensors, energizing Fire/Aux. relays, and verifying through-the-lens test. A momentary switch may be installed in the Control Center for Testing the detector. *Caution: All relay outputs to Control Panel and extinguishing systems must be disabled to prevent system alarms and unwanted extinguishing discharge.*
5. Connecting or shorting terminal labeled "Reset" to 24 VDC (Return) will recycle power resetting the detector to Normal Operation. A momentary switch may be installed in the Control Center for Resetting the detector.

Fig. 4 –Detector Wiring Schematic



3.0 Operation & Startup

Powering the Detector

3.1.1 Once the installation of the detector and wiring are completed, the next step is to power up each detector individually and perform functional tests by generating Fire Alarm and Fault conditions.

NOTE: *When performing functional tests during the start-up or maintenance always check to make sure that the output of the detector to fire suppression systems has been disabled.*

CAUTION: *When performing functional tests during the start-up or maintenance always check to make sure that the output of the detector to fire suppression systems has been disabled.*

3.1.2 LED Status Indicators

Apply power to the detector and wait 1-2 minutes until the detector has completed its diagnostic process and its circuitry has been stabilized. During this process detector LEDs will flash sequentially clockwise several times; once normalized its green LED will remain ON for one second and OFF for one second indicating normal operation.

The detector status is indicated by 3 color LEDs as follows:

Normal Operation: The Green LED will turn ON and OFF every second indicating that the detector is operating properly and there is no Fault or Alarm. If the Green light is not flashing, please check wiring or the 24 VDC power to the detector.

Fault Condition: The Amber LED will turn on and stay on when either a General Fault or Self-Test Fault is detected. The detector will return to Normal when Fault is cleared, and the Amber LED will turn off automatically.





Alarm Condition: The Red LED will turn on indicating that the detector has detected fire. The Red LED will remain on as long as the fire is present and will turn off once the fire has been extinguished. The detector status will then return to Normal Condition with the Green LED flashing



3.1.3 Detector Self-Test:

The **D371SS** detector is programmed to perform an automatic diagnostic self-test periodically (factory default is every 5 minutes). During the automatic Self-Test, the detector will turn on both Amber LEDs flashing for 2-3 seconds. Following the automatic Self-Test, the detector will return to Normal Operation if no Faults were detected. The detector will also monitor the blockage of its viewing window every second using the **OptiRadar** feature. If any object is placed within 2" of detector's window for longer than 60 seconds, the detector will declare a Fault.



OptiRadar
SENSOR



3.1.4 Alarm Test Using the Manual Self-Test

Fire Alarm Test: This test can be done by forcing the detector into its Self-Test Mode. This can be accomplished by connecting (shorting) the terminal #7 of the J2 connector to 24VDC (-) until the Red LED is turned on (Fig. 4, Page 14). **Caution:** *All relay outputs to Control Panel and extinguishing systems must be disabled to prevent system alarms and unwanted extinguishing discharge.*

1. **Detector with “Latching” configuration** - Once in Alarm, 24 VDC (-) should be removed from terminal #7. The detector, however; will remain in Alarm mode until it is reset by momentarily recycling power to detector. To reset the detector simply connect (or short) the terminal #9 of the J2 connector to 24 VDC (-). The detector will then return to Normal.
2. **Detector with “Non-Latching” configuration** - Once the detector is in Alarm, removing 24 VDC(-) from terminal #7 (J2) return the detector automatically to Normal within 5 seconds.

4.0 Maintenance

4.1 Maintenance Requirements

4.1.1 Detector Inspection

The **D371SS** detector does not require calibration at any times after installation. This detector also is not easily affected by dirt, dust, smoke, water and even thin layer of ice built-up on the lens. To maintain the detectors in best working condition and performance it is recommended to inspect and clean the detector periodically. It is very important to keep the detector lens (window) cleaned particularly in heavy industrial facilities and dirty environments. Contaminants such as dirt and oil on the lens may attenuate some of the UV and IR radiation lowering the detector’s sensitivity. The following is a routine maintenance guideline:

1. Inspect and clean the lens once every 6 months in a clean environment or more often in dirty environments.
2. The detector lens is made of Sapphire and thus care should be taken not to use any harsh chemicals or scratcher pads to clean it. A simple cotton cloth or cotton balls using water and mild detergent will be the best option. If oil has accumulated on the lens, use a small amount of IPA solution (Isopropyl Alcohol) and a cotton ball or clean cloth to clean the lens.

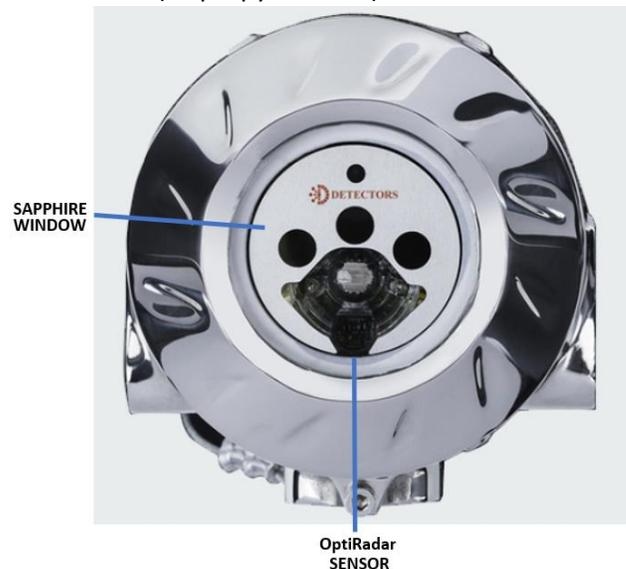



3. Unlike the conventional flame detectors, The **D371SS** has no external reflector or reflector ring for reflecting the IR or UV test source generated by the detector back onto the IR or UV sensors for determining the obscuration due to the build-up of contaminants on the lens. The detector uses its Sapphire window as a “reflector” for self-test purposes and its **OptiRadar** feature to determine the obscuration of the window. The detector will initiate a self-test FAULT if excessive amount of dirt, dust, oil other contaminants accumulate on the lens. Should the contamination on the lens exceed the allowable threshold, the detector will initiate a self-test FAULT.

4.2 Periodic Detector Testing

4.2.1 Functional Testing

Every detector should be functionally tested at least once every 6 to 12 months or as required by the local authorities having jurisdiction. This shall include but not limited a complete “end-to-end test” of all detectors and verifying that all relays and output signals perform per manufacturer’s original Specifications. The detector can be put into Alarm mode as described in Section 3.1.4 and should be used for testing as follows:

1. **Caution: Prior to performing the fire test, ensure that all extinguishing systems are disabled or bypassed.** Follow the procedure outline in Section 3.1.4 forcing the detector into Alarm. Detector’s output signals should be monitored to verify that they are functioning properly.
2. A Fault test can be performed by forcing the detector into a Fault condition. This can be accomplished by lowering the input voltage to the detector to below 18 volts (low voltage fault) and monitoring the status of the Fault relay and Fault LED.

To perform a self-test Fault using the **OptiRadar** feature built into the detector, place a small piece of opaque material such as thin cardboard directly in front of the Window thus blocking the detector’s view. The detector’s Amber LED (Fault) will begin flashing for 60 seconds indicating blockage of the viewing window. Holding the cardboard longer than 60 seconds will turn the flashing Amber LED to steady Amber LED indicating the detector has failed the self- test and has declared a Fault.

4.2.2 Inspecting the Wiring Compartment

In locations with high humidity and rainfall it is recommended to open the back cover and visually inspect inside of the wiring compartment for possible ingress of moisture, clean if needed. Inspect the threads on both the enclosure and the cover. Clean and apply a small amount of Lithium-based grease to keep the threads lubricated. Re-Close the cover and tighten it to the manufacturer’s recommended torque 5-10 ft.-lbs.



5.0 D371SS Detector Response Characteristics

5.1 Performance Testing

The **D371SS** detector, like any other flame detectors, will respond to various types of fires differently both in time and distance. For this reason, the Factory Mutual (FM) baseline performance testing is performed for all flame detectors using 1ft. x 1ft. n-Heptane pan fire for fuel fires and 30"-36" high plume fire for gas flames. This procedure would allow the end-users a means of comparing the flame detectors of various manufacturers for response time and sensitivity. Below is the response characteristic of the **D371SS** detector as tested and witnessed by FM:

Table 4 – Detector Response @ High Sensitivity - Outdoor

Fuel Type	Flame Size	Distance (ft / m)	Response - Seconds (Average)
n-Heptane	12" x 12"	200 / 61	< 10
IPA	12" x 12"	160 / 49	< 12
JP4	12" x 12"	180 / 55.9	< 10
JP4 (Req. Canada)	24" x 24"	200 / 61	< 10
Diesel	12" x 12"	180 / 55	< 8
Methanol	12" x 12"	130 / 40	< 15
Ethanol	12" x 12"	150 / 46	< 10
Methane	36" plume	180 / 55	< 7
Ethane	36" plume	180 / 55	< 7
Propane	36" plume	180 / 55	< 7
Hydrogen	36" plume	120 / 37	< 8

Table 5 – Detector Response @ High Sensitivity - Indoor

Fuel Type	Flame Size	Distance (ft / m)	Response - Seconds (Average)
n-Heptane	2" Dia.	29' 9" / 9	3.43

Table 6 – Detector Response @ Medium Sensitivity - Outdoor

Fuel Type	Flame Size	Distance (ft / m)	Response - Seconds (Average)
n-Heptane	12" x 12"	150 / 46	< 7
IPA	12" x 12"	120 / 37	< 10
JP4	12" x 12"	120 / 37	< 8
JP4 (Req. Canada)	24" x 24"	150 / 46	< 8
Diesel	12" x 12"	120 / 37	< 20
Methanol	12" x 12"	70 / 21	< 8
Ethanol	12" x 12"	120 / 37	< 12
Methane	36" plume	130 / 40	< 8
Ethane	36" plume	150 / 46	< 9
Propane	36" plume	130 / 40	< 8
Hydrogen	36" plume	20 / 6	< 8

Table 7 – Detector Response @ Medium Sensitivity - Indoor

Fuel Type	Flame Size	Distance (ft / m)	Response - Seconds (Average)
n-Heptane	2" Dia.	22' 2"	< 8

Table 8 – Detector Response @ Low Sensitivity - Outdoor

Fuel Type	Flame Size	Distance (ft / m)	Response - Seconds (Average)
n-Heptane	12" x 12"	100 / 30	< 8
IPA	12" x 12"	80 / 24	< 8
JP4	12" x 12"	80 / 24	< 8
JP4 (Req. Canada)	24" x 24"	80 / 24	< 8
Diesel	12" x 12"	70 / 21	< 10
Methanol	12" x 12"	40 / 12	< 11
Ethanol	12" x 12"	70 / 21	< 8
Methane	36" plume	100 / 30	< 10
Ethane	36" plume	100 / 30	< 8
Propane	36" plume	100 / 30	< 10
Hydrogen	36" plume	20 / 6	< 8

Table 9 – Detector Response @ Low Sensitivity - Indoor

Fuel Type	Flame Size	Distance (ft / m)	Response - Seconds (Average)
n-Heptane	2" Dia.	14' 9" / 6	< 8



5.2 Immunity to False Alarm Sources

Detector **D371SS** is highly immune to many false alarm sources tested. Below tables are samples of False Alarm Immunity to various sources and the detector response time in the presence of false alarm sources:

Table 10 – Detector False Alarm Immunity @ High Sensitivity

False Alarm Source	Distance	Unmodulated	Modulated
Sunlight		No Response	No Response
Incandescent Lamp – 60W	3ft / 0.91m	No Response	No Response
Infrared Heater – 1500W	3ft / 0.91m	No Response	No Response
Sodium Vapor Lamp – 150W	3ft / 0.91m	No Response	No Response
Florescent Lamp – 22W	3ft / 0.91m	No Response	No Response
Halogen Lamp – 500W	3ft / 0.91m	No Response	No Response
Mag Flashlight	3ft / 0.91m	No Response	No Response
Heater – 6kW	3ft / 0.91m	No Response	No Response
Arc Welding	9ft / 2.7m	No Response	No Response

Table 11 – Detector Fire Response: Presence of False Alarm Source @ High Sensitivity

False Alarm Source	Fire Size and Fuel	Fire Distance (ft./m)	Unmodulated Response Time Seconds (Ave)	Modulated Response Time Seconds (Ave)
Direct Sunlight	12" x 12" n-Heptane	200 / 60	< 6	< 10
Indirect Sunlight	2" Dia. n-Heptane	29' 5" / 9	< 6	< 6
Incandescent Lamp – 60W	2" Dia. n-Heptane	29' 5" / 9	< 6	< 9
Infrared Heater – 1500W	2" Dia. n-Heptane	29' 5" / 9	< 6	< 6
Sodium Vapor Lamp -	2" Dia. n-Heptane	29' 5" / 9	< 6	< 6
Florescent Lamp	2" Dia. n-Heptane	29' 5" / 9	< 6	< 6
Halogen Lamp – 500W	2" Dia. n-Heptane	29' 5" / 9	< 6	< 9
Mag Flashlight	2" Dia. n-Heptane	29' 5" / 9	< 7	< 7
Heater – 6kW	2" Dia. n-Heptane	29' 5" / 9	< 6	< 6
Arc Welding	2" Dia. N-Heptane	11' 9" / 3.6	< 6	< 4

Table 12 – Detector False Alarm Immunity @ Medium Sensitivity

False Alarm Source	Distance	Unmodulated	Modulated
Sunlight		No Response	No Response
Incandescent Lamp – 60W	3ft / 0.91m	No Response	No Response
Infrared Heater – 1500W	3ft / 0.91m	No Response	No Response
Sodium Vapor Lamp – 150W	3ft / 0.91m	No Response	No Response
Florescent Lamp – 22W	3ft / 0.91m	No Response	No Response
Halogen Lamp – 500W	3ft / 0.91m	No Response	No Response
Mag Flashlight	3ft / 0.91m	No Response	No Response
Heater – 6kW	3ft / 0.91m	No Response	No Response
Arc Welding	9ft / 2.7m	No Response	No Response

Table 13 – Detector Response: Presence of False Alarm Source @ Medium Sensitivity

False Alarm Source	Fire Size and Fuel	Fire Distance (ft./m)	Unmodulated Response Time Seconds (Ave)	Modulated Response Time Seconds (Ave)
Direct Sunlight	12" x 12" n-Heptane	150 / 45	< 6	< 10
Indirect Sunlight	2" Dia. n-Heptane	22' 2" / 6.7	< 6	< 6
Incandescent Lamp – 60W	2" Dia. n-Heptane	22' 2" / 6.7	< 6	< 9
Infrared Heater – 1500W	2" Dia. n-Heptane	22' 2" / 6.7	< 6	< 6
Sodium Vapor Lamp -	2" Dia. n-Heptane	22' 2" / 6.7	< 6	< 6
Florescent Lamp	2" Dia. n-Heptane	22' 2" / 6.7	< 6	< 6
Halogen Lamp – 500W	2" Dia. n-Heptane	22' 2" / 6.7	< 6	< 9
Mag Flashlight	2" Dia. n-Heptane	22' 2" / 6.7	< 7	< 7
Heater – 6kW	2" Dia. n-Heptane	22' 2" / 6.7	< 6	< 6
Arc Welding	2" Dia. N-Heptane	11' 9" / 3.5	< 6	< 4

Table 14 – Detector False Alarm Immunity @ Low Sensitivity

False Alarm Source	Distance	Unmodulated	Modulated
Sunlight		No Response	No Response
Incandescent Lamp – 60W	3ft / 0.91m	No Response	No Response
Infrared Heater – 1500W	3ft / 0.91m	No Response	No Response
Sodium Vapor Lamp – 150W	3ft / 0.91m	No Response	No Response
Florescent Lamp – 22W	3ft / 0.91m	No Response	No Response
Halogen Lamp – 500W	3ft / 0.91m	No Response	No Response
Mag Flashlight	3ft / 0.91m	No Response	No Response
Heater – 6kW	3ft / 0.91m	No Response	No Response
Arc Welding	9ft / 2.7m	No Response	No Response

Table 15 – Detector Response: Presence of False Alarm Source @ Low Sensitivity

False Alarm Source	Fire Size and Fuel	Distance (ft./m)	Unmodulated Response Time Seconds (Ave)	Modulated Response Time Seconds (Ave)
Direct Sunlight	12" x 12" n-Heptane	100' / 30	< 6	< 10
Indirect Sunlight	2" Dia. n-Heptane	14' 9" / 4.5	< 6	< 6
Incandescent Lamp – 60W	2" Dia. n-Heptane	14' 9" / 4.5	< 6	< 9
Infrared Heater – 1500W	2" Dia. n-Heptane	14' 9" / 4.5	< 6	< 6
Sodium Vapor Lamp -	2" Dia. n-Heptane	14' 9" / 4.5	< 6	< 6
Florescent Lamp	2" Dia. n-Heptane	14' 9" / 4.5	< 6	< 6
Halogen Lamp – 500W	2" Dia. n-Heptane	14' 9" / 4.5	< 6	< 9
Mag Flashlight	2" Dia. n-Heptane	14' 9" / 4.5	< 7	< 7
Heater – 6kW	2" Dia. n-Heptane	14' 9" / 4.5	< 6	< 6
Arc Welding	2" Dia. N-Heptane	8' / 2.4	< 6	< 4



6.0 Troubleshooting

This Device is self-contained and does 100% self-diagnostics testing every 5 minutes. I can only provide troubleshooting suggestions regarding the Flame Detector portion of the system.

Below are typical Troubleshooting steps I have put together for the conditions that the device could be in. I only see three different states of operation for this device, Fault, Alarm, and Normal Operation. I hope this is helpful information. You are welcome to call me with any specific questions you may have that are not covered here, we can also set up a zoom meeting as well.

Fault Condition:

Condition 1:

Device Internal Fault, Over Voltage, Over Temperature, or Failed Components

Output

<1 mA = General Fault

Solid Yellow LED

Open Fault Relay

RS485 Communication Fault

Event Log Entry in device internal Memory

Trouble Shooting Steps:

Step 1: Reset/Cycle Power to the device

Step 2: Verify Connections

Step 3: Call the Factory

Condition 2:

Dirty Window

Output

Blinking Yellow LED for 1 Minute, if Maintained for 1 continuous minute the LED will turn solid and the outputs will change state

2mA = Opti-Radar Fault

Solid Yellow LED

Open Fault Relay

RS 485 Communication Fault

Event Log Entry in device internal Memory

Trouble Shooting Steps:

Step 1: Clean the Window

Step 2: Reset/Cycle Power to the device



Step 3: Call the factory

Alarm Condition:

Condition 1:

Alarm to a fire

Output

Solid red LED

20mA = Alarm State

Closed Alarm and Auxiliary Relays

RS 485 Communication Alarm

Event Log Entry in device internal Memory

Troubleshooting Steps:

Step 1: When threat cleared rest power if the device is in Latching mode, if in unlatching the device will rest when the threat is removed.

Condition 2:

Fast response to a flash fire - Blinking Red LED

Output

Blinking red LED

20mA = Alarm State

Closed Auxiliary Relay, Open Alarm Relay

RS 485 Communication Alarm

Event Log Entry in device internal Memory

Troubleshooting Steps:

Step 1: When threat cleared rest power if the device is in Latching mode, if in unlatching the device will rest when the threat is removed.

Condition 3:

Alarm to a false Source

Output

Blinking red LED or Solid red LED

20mA = Alarm State

Closed Auxiliary Relay, Open Alarm Relay or Both Relays will be closed

RS 485 Communication Alarm

Event Log Entry in device internal Memory

Troubleshooting Steps:

Step 1: Verify there is no potential for there to be a fire threat

Step 2: Reset/Cycle Power to the device, if False Alarm condition continues



Step 3: Verify all grounding connection in the powder application are terminated correctly

Step 4: Verify all wire termination in the device are correct.

Step 5: Call the factory

Normal Operation:

Condition 1

Normal Operation

Output

Blinking Green LED

4mA = Normal Operation

Closed Fault Relay Open Alarm and Auxiliary Relays

RS 485 Communication Normal Operation

Event Log Entry stamping the device on time and date

Condition 2

Normal Operation Self Diagnostic every 5 minutes

Output

Blinking Green LED, flashing amber incandescent Lamps to test the sensors

4mA = Normal Operation

Closed Fault Relay Open Alarm and Auxiliary Relays

RS 485 Communication Normal Operation

Event Log Entry only if there is a failure.

Special Condition: If an internal failure is observed by the device the units will retest itself every 1 minute for 5 consecutive minutes. If the fault is still observed the units will declare a fault.

7.0 Event Log & Fire Graph

Fault Event- 2020 . 5 . 12 : 8 : 32 : 28	Voltage Fault: 24VSP, 12VREG, 5VSP, 2.5VREG, 24Vin, Item Fault: Fault Relay, Heater,
Power On- 2020 . 5 . 12 . 8 : 21	Power Off: 2020 . 5 . 12 . 8 : 21 .
Fault Event- 2020 . 5 . 12 : 8 : 32 : 3	Voltage Fault: 24VSP, 12VREG, 5VSP, 2.5VREG, 24Vin, Item Fault: Fault Relay, Heater,
Power On- 2020 . 5 . 12 . 8 : 21	Power Off: 2020 . 5 . 12 . 8 : 21 .
Fault Event- 2020 . 5 . 12 : 8 : 31 : 50	Voltage Fault: 24VSP, 12VREG, 5VSP, 2.5VREG, 24Vin, Item Fault: Fault Relay, Heater,
Fire Event- 2020 . 5 . 11 . 17 : 27 : 17	Temp=22.46 °C, Power=23.26 V. Fire Diagram index= 4
Fire Event- 2020 . 5 . 11 . 16 : 33 : 49	Temp=15.85 °C, Power=23.03 V. Fire Diagram index= 3
Power On- 2020 . 5 . 11 . 15 : 39	Power Off: 2020 . 5 . 11 . 15 : 39 .



Event List – Fire Graph Display

1. Ensure you have a file created on the “C” drive labeled “TEST”. This is going to be the location of all your files.
2. Go to the COMM PORT in the upper left-hand side of the screen and on the drop-down box select your active Comm Port. It will have a white background.
3. On the second line of the top task bar press the “Red” Icon. It should go clear.
4. On the second line of the top task bar press the “White” arrow to start communications.
5. At the bottom left-hand side of the screen label the “File Path” on the “C:\TEST and rename the record to any name c:\test\xxxxxxxxxxxx.txt.
6. Press “Write to file” to create a history log. (c:\test\xxxxxxxxxxxx.txt)
7. Under the Detectors Inc banner press the “Read Event List” to download the history buffer (200 events – first in – first out).
8. In the history buffer records if there was a “Fire Event” it will have create a Fire Diagram index (0-5).
9. At the bottom middle of the screen ensure you have a “File Path 2” window. Change that record to any name c:\test\Fire Graph xxxxxxx.txt
10. Press “Write to file 2” to create a Fire Graph c:\test\Fire Graph xxxxxxx.txt
11. In the middle/center of the screen there is a Up/Down Arrow function to select the number of the fire graph you wish to view and log.
12. Press the Read Fire Event Graph button to start the download. The window box above the graph will give you status of the progress.
13. You can download multiple Fire Event Graphs, just make sure you rename each download.

IMPORTANT. The history buffer only holds 6 graphs. (– first in – first out). To ensure your data can be saved, download files **before** you do any testing, so you do not overwrite existing files. They cannot be recovered once they are overwritten.

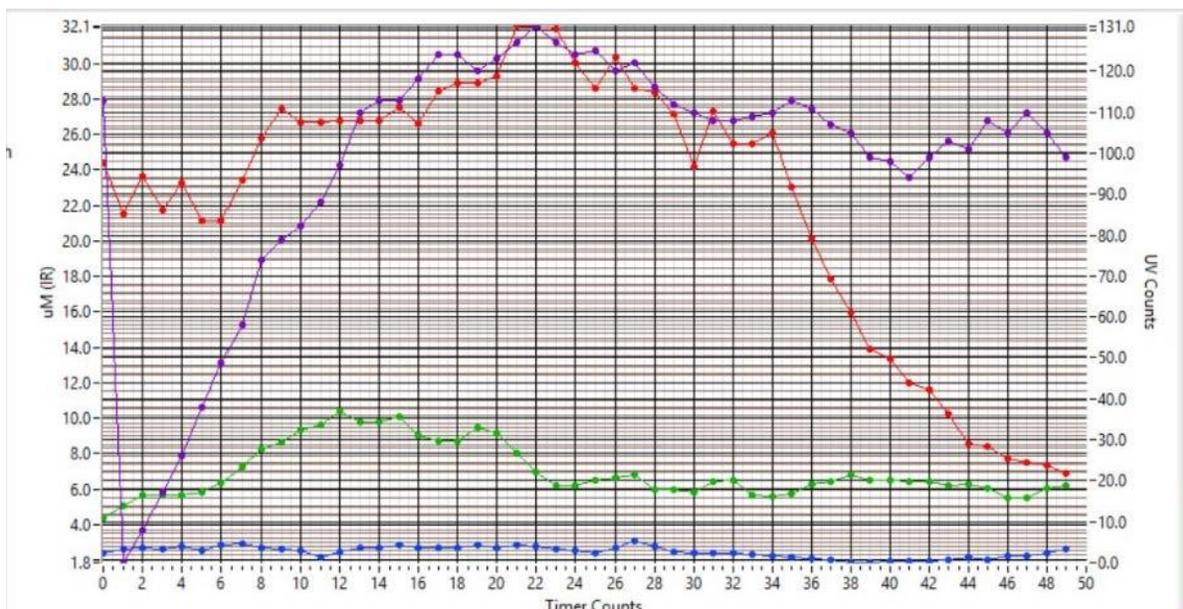



Fire Graph Chart Display

1. Go to your file location in the “C” drive labeled “TEST”. This is the location of your Fire Graph files (0-5).
2. Select the file you want to chart and open the .TXT file in “Notepad” or equal.
3. Click on the “Edit” tab of Notepad and select “Select All”.
4. Click on the “Edit” tab of Notepad and select “Copy”.
5. Open a new Excel worksheet and paste the copied data into space A1.
6. Make sure all the new data is still highlighted/selected.
7. Click on the “Insert Tab” of the Excel worksheet.
8. Go over to the “Charts” section and select 2-D Line Chart

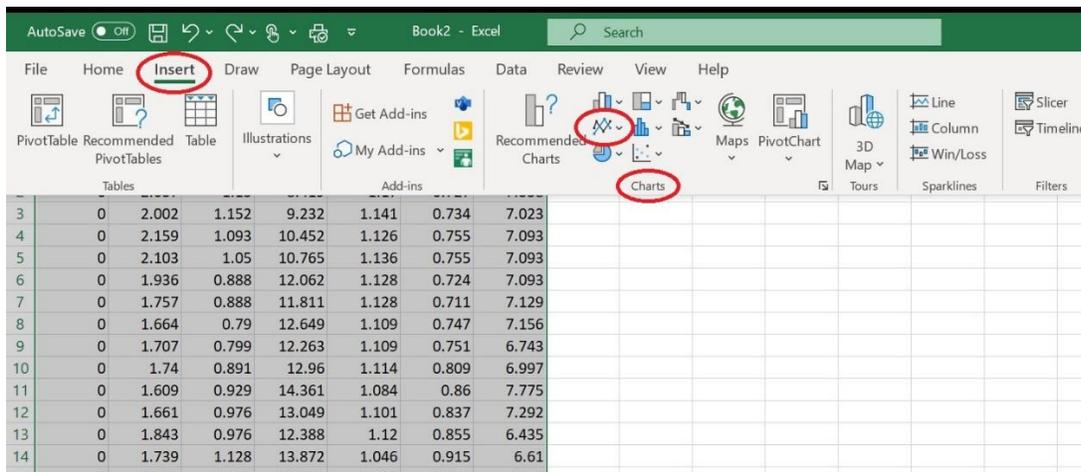

- 9.
10. Once you have click on the 2-D Line Chart you chart will appear.

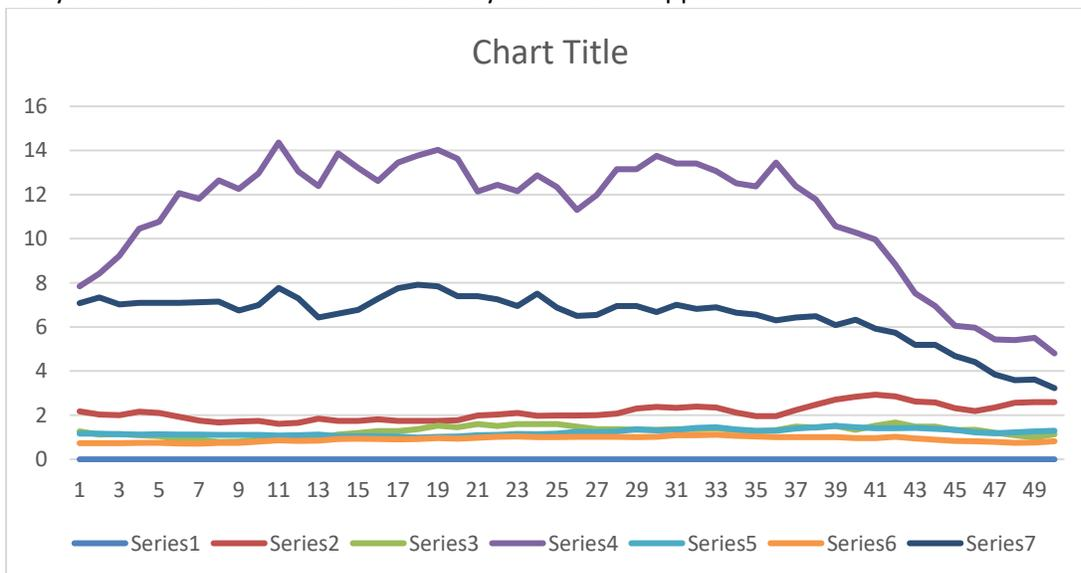

- 11.
12. Label your chart by clicking on “Chart Title”.



8.0 Accessories

ACCESSORIES					
Model		Description	D-171	D-371	D-381
DA-001		316 Stainless Steel Swivel mounting arm for D-171 and D-371 Detectors	☑	☑	
DA-002		316 Stainless Steel Swivel mounting arm with 4 hole mounting plate and Pole mount for D-381 Detectors			☑
DA-003		Air Purge Kit Color Red	☑	☑	☑
DA-004		Test Lamp for D-171 only	☑		
DA-005		Weather/Sun Shield Color Red	☑	☑	
DA-006		Field of View Restrictor	☑	☑	
DA-007		Weather/Sun Shield Color Red			☑



DA-008		Remote Test Switch			
DA-009		Tablet and Software to Download History Buffer and Fire Graphs			
HW-AM25-0001		M25 Male to 3/4" Adaptor Stainless Steel			
HW-AM25-0002		M25 Male to 3/4" Aluminum Adaptor			

9.0 Product Support

9.1 Technical Support and Customer Support For Technical and Customer Support and questions concerning the detectors or applications, please contact:



EMAIL

DTech@detectorsinc.com



PHONE

+1-714-982-5350



ADDRESS

Detectors Incorporated 1800
E. Miraloma Ave., SUITE "A"
Placentia, CA 92870, USA



10.0 Warranty

Detectors Incorporated warrants the products manufactured and supplied by Detectors Incorporated against defects in materials and workmanship under normal use and service for a period of Five (5) years from the date of shipment. Detectors Incorporated at its sole discretion will repair or replace at no charge any products found to be defective during the warranty period. The defective product must be shipped transportation paid to Detectors Incorporated or Distributor/Representative where the products was purchased. This express limited warranty is extended by Detectors Incorporated to the original purchaser only and is not assignable or transferable to any other party.

This warranty does not cover the following:

1. Damage incurred in transit.
2. Defects or damage from misuse, accident, “Act of God”, or neglect.
3. Defects or damage from improper installation, lack of maintenance, improper testing and operation.
4. Defects or damage caused by alterations, unauthorized dis-assemblies, repairs or modifications.
5. Damages caused by applying high voltage, electrical power surge or faulty power supplies.
6. Transportation charges to and from repair facility.
7. Illegal or unauthorized alterations of the firmware/software in the product.

This is the complete warranty for the products manufactured by Detectors Incorporated. Except for the warranty expressed above, Detectors Incorporated disclaims all other warranties express or implied with regards to its products sold. Detectors Incorporated sole liability under this warranty is limited only to repair or replacement of the products and shall not include any liability for consequential or other damages arising from the use of the product.



APPENDIX “A”

D371SS – a b c d – e f

Detectors Model ←

D371SS: 3IR + UV Detector – Stainless Steel Enclosure

Output Options ←

- 1 – 3 Relays, 0-20mA, Modbus, No Heater (Additional Cost Applies)
- 2 – 3 Relays, 0-20mA, Modbus, Heater (Additional Cost Applies)
- 3 – 3 Relays, Modbus, No Heater (Basic Version) (Factory Standard)
- 4 – 3 Relays, Modbus, with heater (Basic Version, (Additional Heater Cost Applies)

Fire Relay Configuration ←

- 1 - Normally De-Energized - Non-Latching (Factory Standard)
- 2 - Normally De-Energized – Latching
- 3 - Normally Energized - Non-Latching
- 4 - Normally Energized – Latching

Auxiliary Relay Setting ←

- A - 0.3 Seconds Early Warning
- B - Redundant Alarm (Factory Standard)
- C - 10 Second Verify
- D - 20 Seconds Verify

Fault Relay Configuration ←

- 1 - Normally Energized - Non-Latching (Factory Standard)
- 2 - Normally Energized - Latching

Conduit Entries ←

- M - (2) x M25 openings, Includes 1 M25 x 3/4 Explosion Proof Conduit Adapter (Factory Standard)
- N – 1 Additional M25 x 3/4 Explosion Proof Conduit Adapter (2 Total) (Additional Cost Applies)
- O – (2) x M25 openings, No Adapters

Sensitivity ←

- 1 - 100 Feet - FOV 90 Degrees (Factory Standard)
- 2 - 150 Feet - FOV 90 Degrees
- 3 - 200 Feet - FOV 60 Degrees

Factory Default Configuration: D371SS – 3 1 B 1 – M 1



APPENDIX “B”

Approvals & Certifications - Detector D371SS



Certification No: **FMI7US0336X**
 Class I, Div. 1, Groups A, B, C and D; Ta = -40°C to +110°C
 Class II/ II, Groups E, F and G; T4, -40°C to +85°C
 T4 = -40°C to +85°C, T5 = -40°C to +75°C, T6 = -40°C to +60°C

Class I, Zone 1 AEx db eb IIC T4 Gb, Ta = -40°C to +110°C
 AEx tb IIIC 135°C Db T4, Ta = Ta = -40°C to +110°C
 T4 = -40°C to +85°C, T5 = -40°C to +75°C, T6 = -40°C to +60°C
 Type 4X and IP66/IP67



Certification No: **FMI7CA0120X**
 Class I, Div. 1, Groups A, B, C and D; T4, Ta = -40°C to +110°C
 Class II/ II, Groups E, F and G; T4, Ta = -40°C to +110°C
 T4 = -40°C to +85°C, T5 = -40°C to +75°C, T6 = -40°C to +60°C

Class I, Zone 1 Ex db eb IIC T4 Gb, Ta = -40°C to +110°C
 Ex tb IIIC 135°C Db T4, Ta = Ta = -40°C to +110°C
 T4 = -40°C to +85°C, T5 = -40°C to +75°C, T6 = -40°C to +60°C
 Type 4X and IP66/IP67



Certificate Number: **FMI7ATEX0101X**
 (II 2 G) Ex db eb IIC T4 Gb, Ta = -40°C to +110°C
 (II 2 D) Ex tb IIIC T135°C Db, Ta = -40°C to +110°C
 T4 = -40°C to +85°C, T5 = -40°C to +75°C, T6 = -40°C to +60°C
 IP66/ IP67



Certificate Number: **IECEx FMG 17.0034X**
 Zone 21, AEX tb IIIC 135°C Db T4, Ta = Ta = -40°C to +110°C
 T4 = -40°C to +85°C, T5 = -40°C to +75°C, T6 = -40°C to +60°C
 Ex db eb IIC T4 Gb, Ta = -40°C to +110°C
 Ex tb IIIC T135°C Db, Ta = -40°C to +110°C
 T4 = -40°C to +85°C, T5 = -40°C to +75°C, T6 = -40°C to +60°C
 IP66/ IP67



Meets or Exceeds MIL-STD 810C. In Compliance with
 FM 3260-2003